

MEGANITE®

TECHNICAL
BULLETINS

SPARKLE AESTHETIC AND GREY-TONE DECOR
FABRICATION RECCOMENDATIONS

DOCUMENT PURPOSE

This document offers recommended new fabrication colors containing “sparkle aesthetic.”

September 2015, Meganite Inc. introduces a new exciting aesthetic containing millions of light reflective flakes, implemented thru the full thickness of the sheet. To take full advantage of this new reflective technology, Meganite Inc. recommends the following fabrication techniques for the below decors:

508SA Starry Starry Night
698SA Red Diamond Sparkle
721SA Ice Storm
930SA Silver Shards
933SA Solar Eclipse

519SA Rain Cloud
703SA Snow Owl
819SAR Goldrush Gemstone
931SA Bird Bath

531SA Starry White
704SA Urban Habitat
820A Botanic Gemstone
932SA Mottled Gray

Please review and advise your fabricator, design, architects, millwork, etc.

SURFACE APPEARANCE

Sheets are directional, with the light reflective flakes flowing lengthwise thru the sheet, be sure to layout jobs with sheets running in the same direction for a consistent appearance. This skill is most important in L-shaped and U-shaped projects and will ensure that the reflective material flows nicely around corners and the seams remain inconspicuous.

Illustrations below show the most effective fabrication techniques for L-shaped and U-shaped projects.

***All illustrations are for layout reference, seam off-sets, inside radius', seam plates, etc. are still required.**

Because the directional flow of the sheet is very subtle, it is recommended to mark the underside of the sheets with directional arrows, upon receipt of the sheet and before cutting your project parts. See Figure 1.

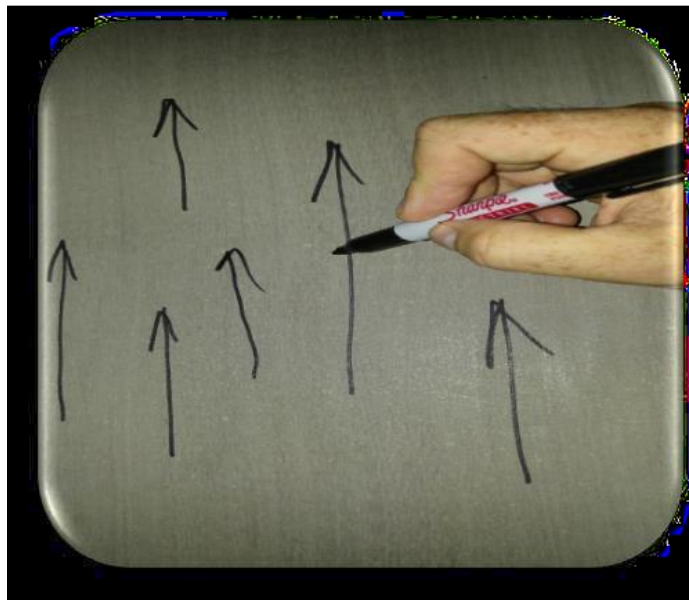

Figure 1 manually mark direction on sheet in multiple areas before cutting

SHEET LAYOUT

Layout L-shape and U-shape countertops properly, keeping sheets in the same direction. See Figure 2 & 3.

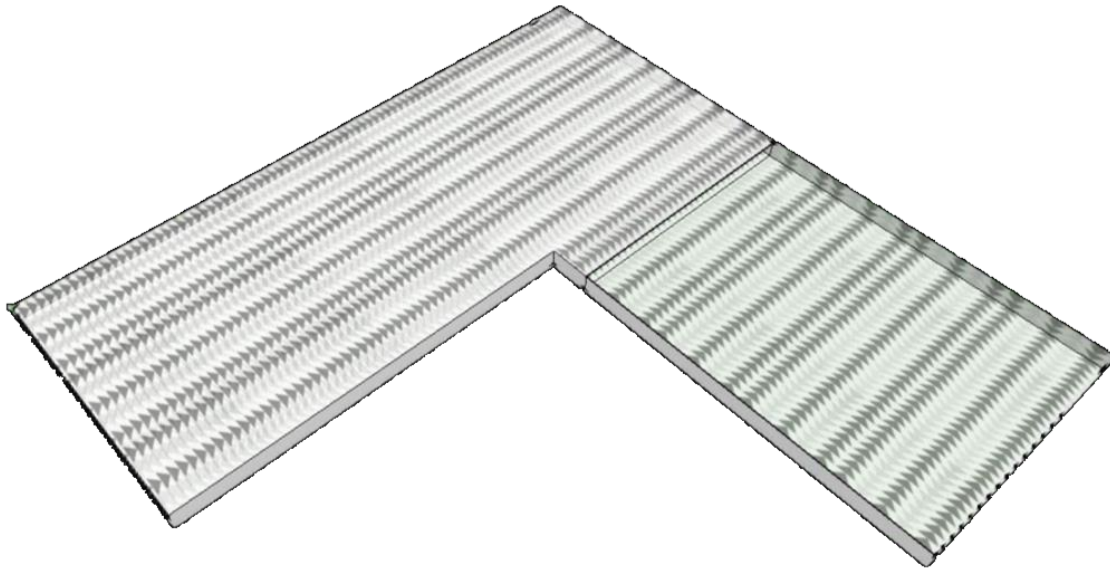

Figure 2 illustration of L-shape countertops - keep all parts running in the same direction

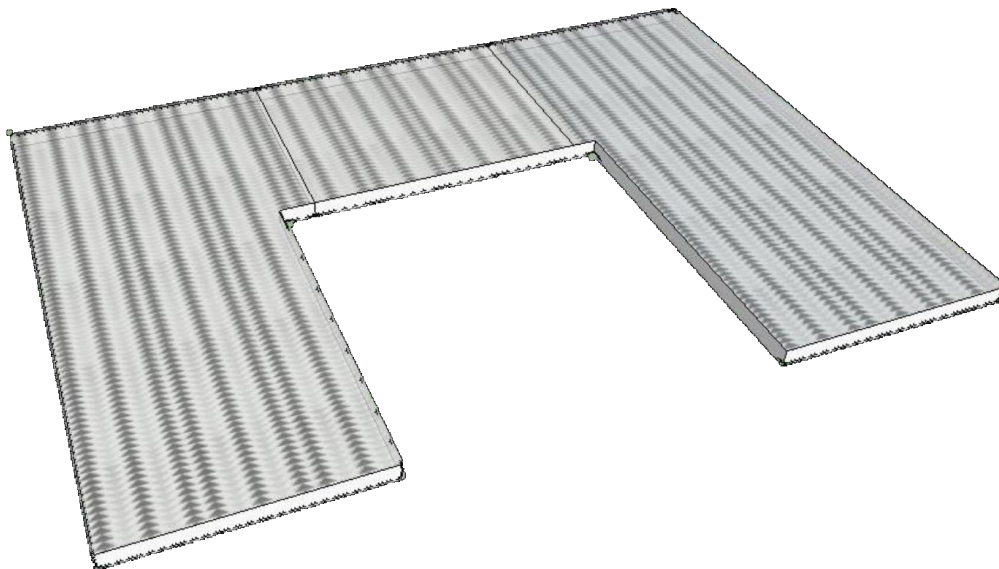

Figure 3 illustration of U-shape countertops - keep all parts running in the same direction

Edge Treatments

Mitered-edges maximize surface exposure and flake reflection. Follow this fabrication skills to get the best color flow and consistency. See Figure 4 & 5.



Figure 4 illustration on mitered-edge



Figure 5 Sample of mitered-edge

Edge Treatments - continued

Stacked-edges give the best appearance from top to edge. See Figure 6 & 7.

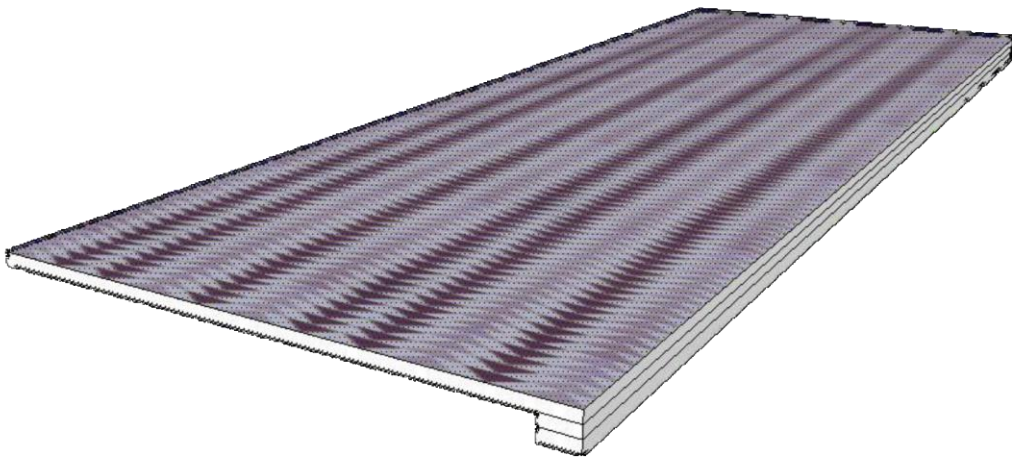

Figure 6 illustration on stacked-edge



Figure 7 Sample of stacked-edge

MEGANITE®

TECHNICAL
BULLETINS

SPARKLE AESTHETIC AND GREY-TONE DECOR
FABRICATION RECCOMENDATIONS

Edge Treatments - continued

Drop-edges are NOT recommended as they will highlight the shade differences between the top and edge. See figure 8 & 9.

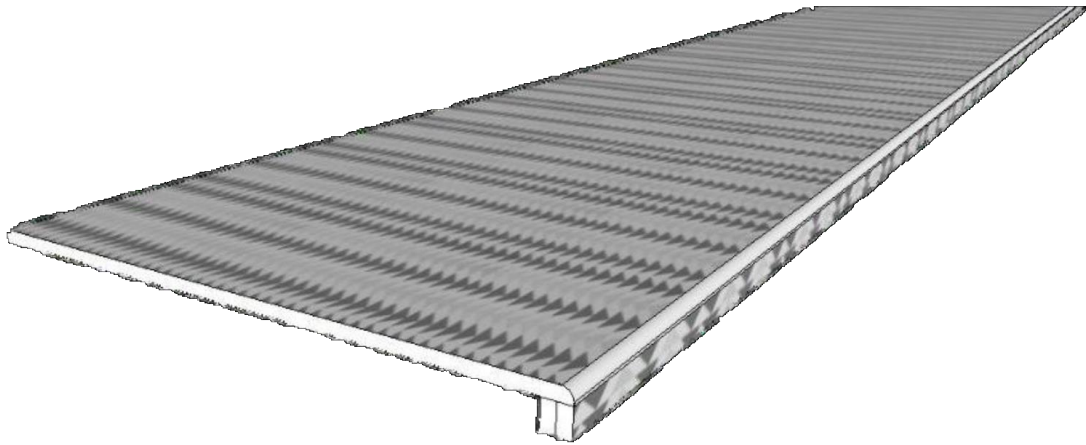

Figure 8 illustration on drop-edge

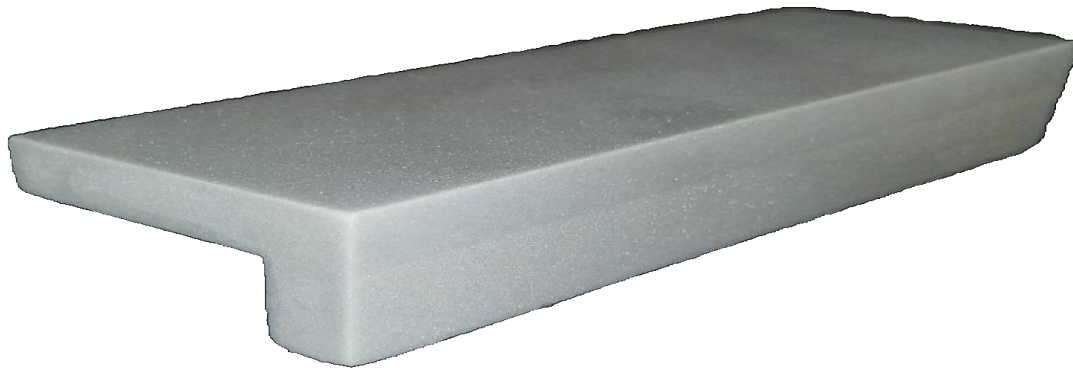

Figure 9 drop-edge demonstration

IF YOU HAVE QUESTIONS, PLEASE CONTACT MEGANITE SOLID SURFACE REPRESENTATIVES,
AUTHORIZED FABRICATORS, DISTRIBUTORS OR EMAIL US AT INFO@MEGANITE.COM.
ALL TECHNICAL BULLETINS CAN BE FOUND @ WWW.MEGANITE.COM